

# Section 5A: Guide to Designing with AAC

5A.1 Introduction .....	3
5A.3 Hebel Reinforced AAC Panels .....	4
5A.4 Hebel AAC Panel Design Properties .....	6
5A.5 Hebel AAC Floor and Roof Panel Spans .....	6
5A.6 Deflection .....	12
5A.7 Cantilevers .....	12
5A.8 Support .....	12
5A.9 Shop Drawing Phase .....	13
5A.10 Production .....	13
5A.11 Post Production - Panel Cuts and Openings .....	13
5A.12 Grouting .....	14
5A.13 Storage at the Construction Site .....	14
5A.14 Hebel AAC Panel Design Examples .....	15



## 5A.1 Introduction

This Design Guide was prepared by Xella Aircrete North America, Inc., to help owners, design professionals, and construction managers design, specify and complete building systems that utilize Hebel AAC Block Units and Hebel AAC Floor and Roof Panels. Xella Aircrete North America, Inc. is dedicated to providing information needed to incorporate Hebel AAC materials into any building system.

We have attempted to provide some general information regarding various areas of design and details. However, since we cannot cover all areas or possibilities, we encourage and trust that you will ask for additional information regarding specific areas or possibilities.

If you have questions or need additional information, please contact Xella Aircrete North America, Inc.

Xella Aircrete North America, Inc.

2400 Hebel Boulevard

Adel, GA 31620

Phone: 229-896-1593

Toll Free: 1-877-41-Hebel (1.877.414.3235)

Email: [hebel-usa@xella.com](mailto:hebel-usa@xella.com)

Web: [www.buildwithhebel.com](http://www.buildwithhebel.com)

## 5A.2 Hebel AAC Block Units

Hebel AAC block units can be designed as unreinforced or reinforced load bearing and non-load bearing walls. Hebel block units are manufactured as solid units varying in size ranges, see Table 5A.1. When the design requires steel reinforcing, cored blocks can be factory produced or field cored to match reinforcement spacing required from engineered calculations. Hebel AAC blocks are available in u-shaped cross sections to accommodate the need for lintel beams over wall openings, code required horizontal reinforcing, and continuous bond beams at floor and top of wall elevations.

Building materials qualifying as masonry type elements are designed under the Building Code Requirements for Masonry Structures (ACI 530/ASCE 5/TMS 402) and must comply with the requirements of Specification for Masonry Structures (ACI 530.1/ASCE 6/TMS 602). The 2005 specification includes provisions for designing with AAC block units in Appendix A. The design methodology is entirely based on strength design, using load factors applied to the required strength and resistance factors on the nominal strength. Design examples can be found in the following publications:

- ◇ Masonry Designer's Guide, Fifth Edition (MDG-5)
- ◇ ACI SP-226: Autoclaved Aerated Concrete, Properties and Structural Design.
- ◇ ACI 523.4R-09: Guide for Design and Construction with Autoclave Aerated Concrete Panels.

## 5A.3 Hebel Reinforced AAC Panels

The Hebel reinforced AAC panels are manufactured based on the requirements for each specific project according to the design requirements provided by the customer. In coordination with the final contract documents (Architectural, Structural and Mechanical drawings), the panel layout which includes the length, thickness and width of the panels are developed and defined in conjunction with input from the customer's design team during the Hebel shop drawing phase. The panels are designed, detailed and issued for production after approval of the Hebel shop drawings by the customer's design professionals. In order to achieve production and construction optimization, the Hebel floor and roof panel layout are predicated on a standard panel width 2'-0" (610 mm).

**Table 5A.1: AAC Block Product Line**

1. Block	Thickness		Height	Length	Strength Classes			
	Nominal:	1", 2", 3", 4", 6", 8", 10" & 12"				8"	24"	AAC-2 AAC-4
	Actual <sup>1</sup> :	1" (25 mm), 1 15/16" (50 mm), 2 15/16" (75 mm), 3 15/16" (100 mm), 5 7/8" (150 mm), 7 7/8" (200 mm), 9 13/16" (250 mm), & 11 13/16" (300 mm)				7 7/8" (200 mm)	24 1/16" (610 mm)	
2. Shaft Block	Thickness		Height	Length	Strength Classes			
	Nominal:	3" & 4"				24"	24"	AAC-2 AAC-4
	Actual <sup>1</sup> :	2 15/16" (75 mm) & 3 15/16" (100 mm)				24 1/16" (610 mm)	23 5/8" (600 mm)	
3. Jumbo Block	Thickness		Height	Length	Strength Classes			
	Nominal:	6", 8", 10" & 12"				24"	40"	AAC-2 AAC-4
	Actual <sup>1</sup> :	5 7/8" (150 mm), 7 7/8" (200 mm), 9 13/16" (250 mm), & 11 13/16" (300 mm)				24 1/16" (610 mm)	39 3/8" (1,000 mm)	
4. Mini-Jumbo Block	Thickness		Height	Length	Strength Classes			
	Nominal:	6", 8", 10" & 12"				24"	24"	AAC-2 AAC-4
	Actual <sup>1</sup> :	5 7/8" (150 mm), 7 7/8" (200 mm), 9 13/16" (250 mm), & 11 13/16" (300 mm)				24 1/16" (610 mm)	23 5/8" (600 mm)	

Note: 1. Imperial measurements rounded to nearest 1/16".

Hebel AAC Vertical Non-Load Bearing Wall Panels are reinforced panels spanning a full story height or horizontally between building columns. Available nominal thicknesses are 4", 6", 8", 10" and 12". The Hebel system is based on a standard two foot wide module. The thickness and story height vary depending on the design requirements and constraints of the project. Design guidelines for AAC reinforced panels are in the ACI SP-226: Autoclaved Aerated Concrete, Properties and Structural Design and ACI 523.4R-09: Guide for Design and Construction with Autoclave Aerated Concrete Panels.

The Hebel AAC Vertical Load Bearing Wall Panel system includes the following components: full height panels, jamb panels, lintel panels and sill panels. However, other items should be considered during a Hebel – Vertical Load Bearing Wall Panel installation. Due to design or installation requirements, lintel panels may be used in conjunction with or substituted by steel headers, precast concrete lintels or cast-in-place concrete. In situations where small in-fill is required, Hebel AAC Block may be specified. Hebel AAC Lintels are manufactured in 8", 12" and 24" heights for a maximum opening width of 8'-8". Reference Table 5A.5 for selecting lintels based on design loads.

## 5A.4 Hebel AAC Panel Design Properties

**Table 5A.2: Characteristics of Hebel AAC Products (In Imperial Units)**

Characteristics	AAC-2 /400	AAC-2 /500	AAC-4 /500 <sup>(2)</sup>	AAC-4 /600	AAC-6 /700600	Units
Nominal Dry Density Range	22-28	28-34	28-34	34-41	41-4734-41	pcf
Design Weight Range <sup>(1)</sup>	26-34	34-41	34-41	41-49	49-5641-49	pcf
Minimum Compressive Strength	290	290	580	580	870	psi
Modulus of Elasticity	195,000	195,000	296,000	296,000	377,000	psi
Thermal Expansion Coefficient	$4.5 \times 10^{-6}$	$4.5 \times 10^{-6}$	$4.5 \times 10^{-6}$	$4.5 \times 10^{-6}$	$4.5 \times 10^{-6}$	1/°F
Moisture Content (Average)	8	8	8	8	8	% (by mass)
(1) Values consider material's moisture content (2) Hebel AAC is manufactured based on the strength category AAC-4/500, unless indicated otherwise.						

## 5A.5 Hebel AAC Floor and Roof Panel Spans

Typically, design requirements dictate that the thickness of the Hebel AAC floor and roof panels is a function of the specified span, superimposed dead and live loads. Reference Table 5A.3 & Table 5A.4. Optimization of the panelized system is achieved by utilizing the standard 2'-0" panel width. While Hebel AAC panels can be manufactured as narrow as 12", panel location, loading conditions, and proximity to openings are just a few of the considerations the project design professional must address when designing with AAC reinforced panels. Diagram 5A.1 is provided to help develop Architectural and Structural plans when using Hebel AAC panels (contact Xella Technical Services for assistance with additional questions).

**Diagram 5A.1: Guide for Layout of Hebel Floor and Roof Panels**

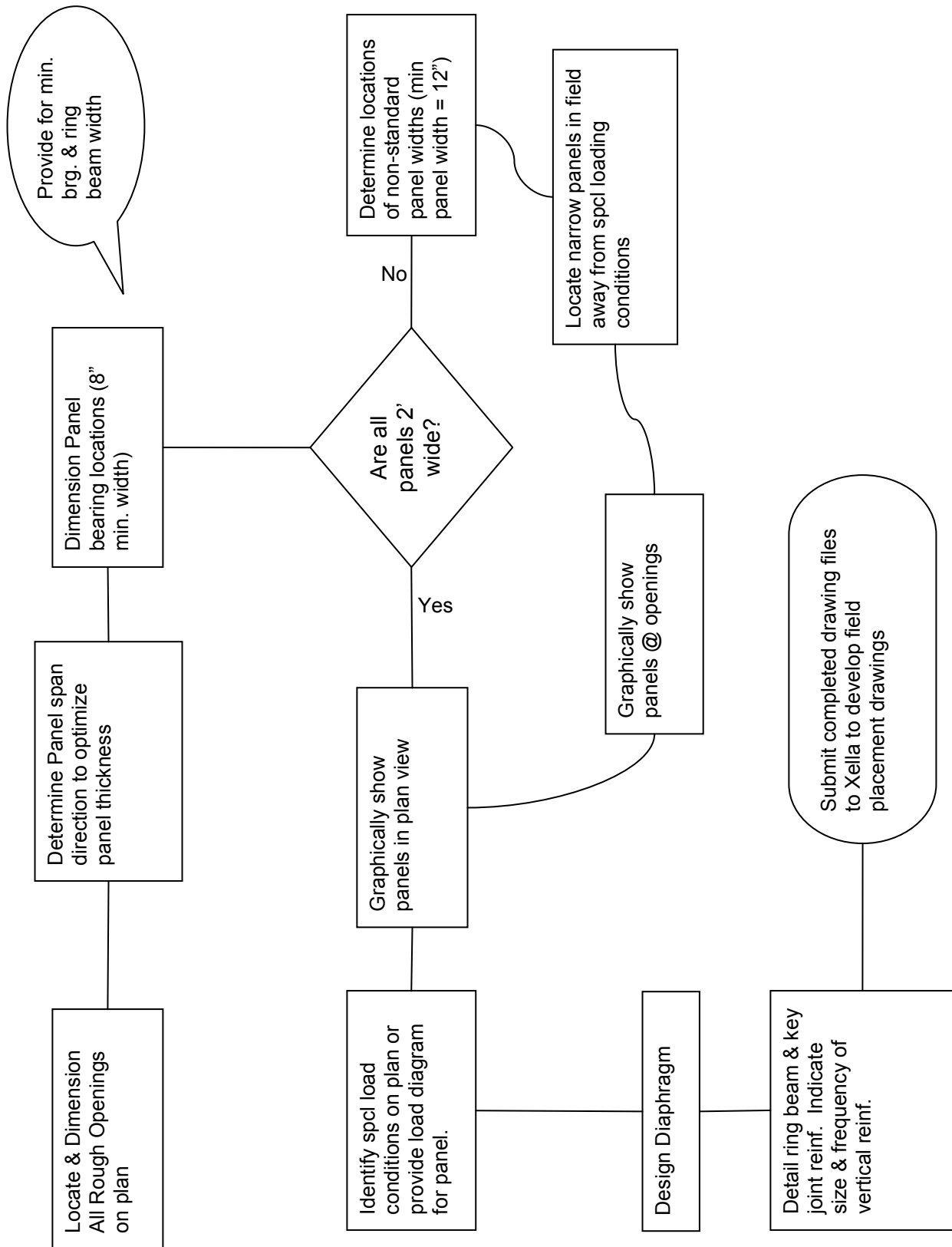

**Table 5A.3: Preliminary Floor Panel Thickness Selection**

<b>Maximum Permissible Span (feet) for Allowable Superimposed Uniform Loads</b>					
<b>Superimposed Loads</b>		<b>Panel Thickness (inches)</b>			
<b>Dead Load (psf)</b>	<b>Live Load (psf)</b>	<b>6</b>	<b>8</b>	<b>10</b>	<b>12</b>
10	20	13.00'	16.25'	19.25'	19.67'
	30	12.00'	15.00'	18.00'	19.67'
	40	11.25'	14.50'	17.00'	19.50'
	50	10.75'	13.75'	16.25'	18.75'
	60	10.25'	13.25'	15.75'	18.00'
	80	9.25'	12.25'	14.50'	16.50'
	100	8.25'	11.25'	13.75'	15.25'
15	20	12.50'	15.75'	18.50'	19.67'
	30	11.75'	14.75'	17.50'	19.67'
	40	11.00'	14.00'	16.75'	19.00'
	50	10.50'	13.50'	16.00'	18.25'
	60	10.00'	13.00'	15.50'	17.50'
	80	9.25'	12.00'	14.50'	16.25'
	100	8.00'	11.00'	13.50'	15.00'
20	20	12.00'	15.25'	18.00'	19.67'
	30	11.25'	14.50'	17.00'	19.50'
	40	10.75'	13.75'	16.25'	18.75'
	50	10.25'	13.25'	15.75'	18.00'
	60	9.75'	12.75'	15.25'	17.50'
	80	9.25'	11.75'	14.25'	16.00'
	100	7.75'	10.75'	13.25'	14.75'

1. All panels meet or exceed  $l/360$  live load and  $l/240$  total load vertical deflections at the allowable loads indicated.
2. The permissible spans listed are to centerlines of support, based on 3" bearing. Maximum overall length of panels is 19'-8". Minimum space between panel ends equals 2".
3. Tabulated spans are for uniform loads on simply supported panels only. Contact your Xella representative for non-uniform loading conditions or uniform loads not listed above. Linear interpolation between tabulated values is not allowed.
4. Since all panels are detailed for a specific project, maximum span lengths may vary from tabulated values.
5. Tabulated panel thicknesses are nominal imperial dimensions. Actual thicknesses are 150 mm, 200 mm, 250 mm, and 300 mm.
6. This table is intended to provide information for determining preliminary panel thicknesses and does not replace the judgment of a qualified design professional.
7. Information subject to change without notice. Refer to Xella Aircrete North America, Inc. website below for most current information.

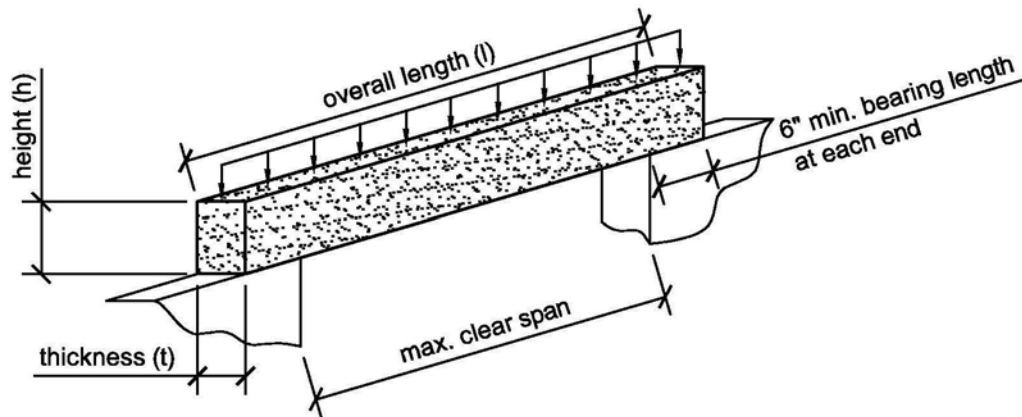

**Table 5A.4: Preliminary Roof Panel Thickness Selection**

Maximum Permissible Span (feet) for Allowable Superimposed Uniform Loads					
Superimposed Loads		Panel Thickness (inches)			
		6	8	10	12
Dead Load (psf)	Live Load (psf)				
10	20	13.75'	17.25'	19.67'	19.67'
	30	12.75'	16.00'	19.00'	19.67'
	40	12.00'	15.25'	18.00'	19.67'
	50	11.50'	14.50'	17.25'	19.00'
	60	11.00'	14.00'	16.50'	18.00'
	80	10.00'	13.00'	15.00'	16.50'
	100	8.25'	11.25'	14.00'	15.25'
15	20	13.25'	16.50'	19.50'	19.67'
	30	12.25'	15.75'	18.50'	19.67'
	40	11.75'	15.00'	17.50'	19.67'
	50	11.25'	14.25'	17.00'	18.75'
	60	10.75'	13.75'	16.25'	17.75'
	80	9.50'	12.75'	14.75'	16.25'
	100	8.00'	11.00'	13.50'	15.00'
20	20	12.75'	16.00'	19.00'	19.67'
	30	12.00'	15.25'	18.00'	19.67'
	40	11.50'	14.50'	17.25'	19.25'
	50	11.00'	14.00'	16.50'	18.25'
	60	10.50'	13.50'	16.00'	17.50'
	80	9.25'	12.50'	14.50'	16.00'
	100	7.75'	10.75'	13.25'	14.75'

1. All panels meet or exceed  $l/240$  live load and  $l/180$  total load vertical deflections at the allowable loads indicated.
2. The permissible spans listed are to centerlines of support, based on 3" bearing. Maximum overall length of panels is 19'-8". Minimum space between panel ends equals 2".
3. Tabulated spans are for uniform loads on simply supported panels only. Contact your Xella representative for non-uniform loading conditions or uniform loads not listed above. Linear interpolation between tabulated values is not allowed.
4. Since all panels are detailed for a specific project, maximum span lengths may vary from tabulated values.
5. Tabulated panel thicknesses are nominal imperial dimensions. Actual thicknesses are 150 mm, 200 mm, 250 mm, and 300 mm.
6. This table is intended to provide information for determining preliminary panel thicknesses and does not replace the judgment of a qualified design professional.
7. Information subject to change without notice. Refer to Xella Aircrete North America, Inc. website below for most current information.

**Table 5A.5: Hebel AAC Lintels – Allowable Vertical Design Loads**



Lintel Size t x h x l	Length	Maximum Clear Span Opening	Allowable Superimposed Uniform Load (lbs./ft.)
8" x 8" x 56"	4'-8"	3'-8"	265
8" x 12" x 72"	6'-0"	5'-0"	950
8" x 12" x 96"	8'-0"	7'-0"	540
8" x 12" x 120"	10'-0"	9'-0"	327
8" x 24" x 72"	6'-0"	5'-0"	2157
8" x 24" x 96"	8'-0"	7'-0"	1446
8" x 24" x 120"	10'-0"	9'-0"	1138

**Notes:**

1. For lengths not shown, use the allowable superimposed uniform load for the next longest lintel length shown.
2. All lintels meet or exceed  $l/360$  vertical deflection at the allowable loads indicated.
3. Loads indicated above are for uniform loading condition only on simply supported span. For concentrated loads contact Hebel Technical Services Department.
4. Allowable superimposed uniform loads listed are vertical loads. For horizontal loads, see Allowable Horizontal Design Loads. For vertical and horizontal loads applied simultaneously, a combined loading check using the straight line interaction formula is recommended.
5. Above lintels can be made in 10" and 12" thicknesses using allowable superimposed uniform loads from table above.
6. The self-weight of the Hebel lintels can be calculated using 46 pcf.
7. Information subject to change without notice. Refer to Xella Aircrete North America website below for most current information.

**Table 5A.6: Hebel AAC Lintels - Allowable Horizontal Design Loads**

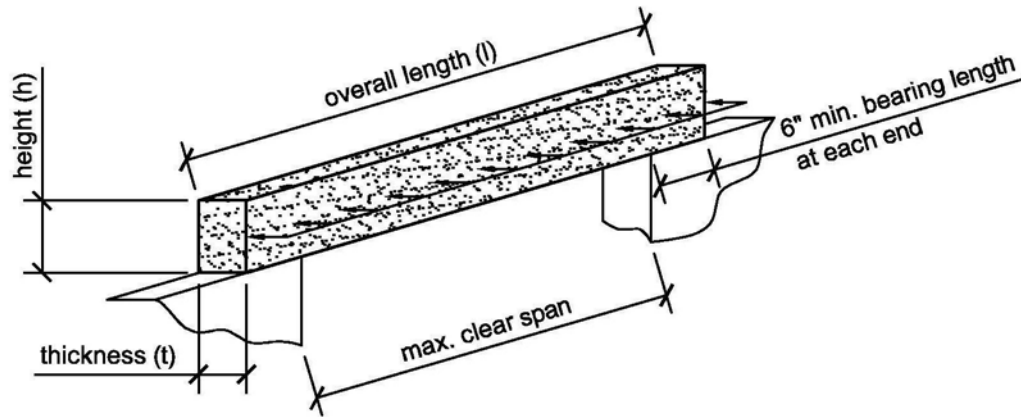

Lintel Size t x h x l	Length	Maximum Clear Span Opening	Allowable Uniform Load (lbs./ft.)
8" x 8" x 56"	4'-8"	3'-8"	265
8" x 12" x 72"	6'-0"	5'-0"	237
8" x 12" x 96"	8'-0"	7'-0"	185
8" x 12" x 120"	10'-0"	9'-0"	109
8" x 24" x 72"	6'-0"	5'-0"	489
8" x 24" x 96"	8'-0"	7'-0"	393
8" x 24" x 120"	10'-0"	9'-0"	237

**Notes:**

1. For lengths not shown, use the allowable uniform load for the next longest lintel length shown.
2. All lintels meet or exceed  $l/360$  horizontal deflection at the allowable loads indicated.
3. Loads indicated above are for uniform loading condition only on simply supported span. For concentrated loads contact Hebel Technical Services Department.
4. Allowable uniform loads listed are horizontal loads. For vertical loads, see Allowable Vertical Design Loads. For vertical and horizontal loads applied simultaneously, a combined loading check using the straight line interaction formula is recommended.
5. Above lintels can be made in 10" and 12" thicknesses using allowable superimposed uniform loads from table above.
6. Information subject to change without notice. Refer to Xella Aircrete North America website below for most current information.

## 5A.6 Deflection

The maximum allowable elastic deflection of Hebel floor panels, based on the total load, is calculated as the panel length (L) divided by 240 (L/240). The maximum allowable elastic deflection for the live load only is calculated as the panel length (L) divided by 360 (L/360). The maximum allowable elastic deflection of Hebel roof panels, based on the total load, is calculated as the panel length (L) divided by 180 (L/180). The maximum allowable elastic deflection for the live load is calculated as the panel length (L) divided by 240 (L/240).

## 5A.7 Cantilevers

A floor and roof panel cantilever is permitted when the length of the cantilever is not more than 1/5 of the panel length or 1/3 of the panel width. If a greater length is required, please contact a Hebel Technical Representative. Engineer of Record is responsible for all connection details of panel diaphragm to support structure.

## 5A.8 Support

The length of bearing required for Hebel floor and roof panels is illustrated in Diagram 5A.2.

Diagram 5A.2: Minimum Bearing Requirements

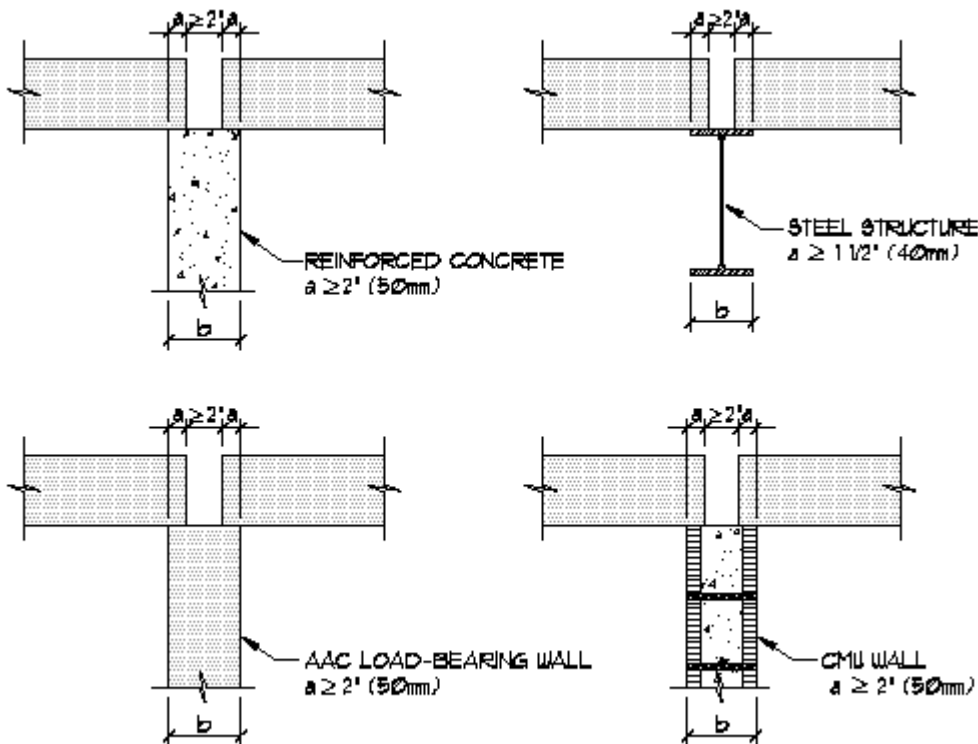

## 5A.9 Shop Drawing Phase

The Hebel shop drawing phase is the development of CAD drawings and panel schedule for the production and construction panel layout which is based on the final contract documents (Architectural, Structural and Mechanical Drawings as well as the project specifications). The Hebel shop drawings are created and issued to the customer's design team for approval, based on the requirements established by the design team. The drawings include the panel layout, rough openings, penetrations, support and bearing conditions which originated from the final construction documents. Based on the approved shop drawings, the panel schedule is developed and the panels are produced and detailed according to the specified loadings with the required reinforcement and strength class. The panel schedule and drawings are then issued to production and construction services.

## 5A.10 Production

The Hebel floor and roof panels are manufactured in accordance with ASTM standards which define the strength category for AAC materials. Floor and roof panels are designed and manufactured based on strength category AAC4/500. The Hebel panel lengths are available in 1/2" (12mm) increments with a maximum length of 19'-8" (5995mm). The standard panel width is 2'-0" (610 mm). The Hebel floor and roof panel thickness of 6" (150mm), 8" (200mm), 10" (250mm) or 12" (300 mm) is available. After the approved Hebel shop drawings and panel schedule are issued to production, panels proceed through production planning and the AAC manufacturing process.

## 5A.11 Post Production - Panel Cuts and Openings

The Hebel floor and roof panels may be cut or notched at various angles on the panel. In the Hebel shop drawing phase, the size, location and type of opening/penetration are coordinated between Hebel and the customer's design professionals to avoid field modifications. The panel reinforcement and layout is designed according to the opening/penetration requirements. The allowable openings and notches within a given panel are defined in Diagram 5A.3.

### Diagram 5A.3: Panel Cuts and Openings

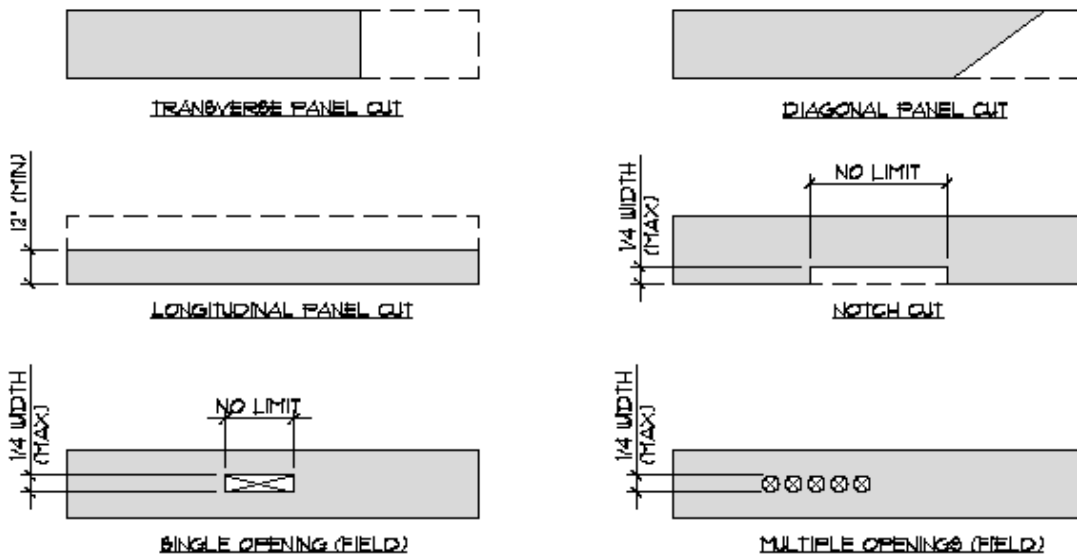

**Caution:** Concrete dust contains quartz silica, a potential human carcinogen. Inhalation of concrete dust above required or recommended exposure levels may be harmful. Wet sawing is recommended. Please consult the Xella Material Safety Data Sheet for further details.

### 5A.12 Grouting

The joints are filled with cement grout on the basis of one part cement and three parts sand. Do not grout the joints and ring beam when the panel temperatures are below 32°F. Do not load the Hebel floor and roof panels before the joint grout and ring beam has set and cured to the minimum compressive strength established by the customer's design professionals.

### 5A.13 Storage at the Construction Site

The Hebel floor and roof panels are packaged and banded together on wood pallets. The panel storage must be supported at one-fifth the overall length from each end. Do not install intermediate supports between the end bearing points of the panels. Protect the Hebel panels from the deleterious material.

**Note:** Xella Aircrete North America, Inc. recommends that the customer's design professionals consult and coordinate his decisions, judgment and design with the engineer or architect of record.

## 5A.14 Hebel AAC Panel Design Examples

### Diaphragm Design Procedure

$$\text{Tensile chord force ( } T_c \text{): } T_c = \frac{M}{jH}$$

where  $M$  is the design moment of the diaphragm, ' $j$ ' is taken as unity (1.0), and ' $H$ ' is the depth of the diaphragm.

$$\text{Allowable shear for a grouted joint or concrete bond beam ( } V_g \text{): } V_g = F_v(a)$$

where  $F_v$  is the allowable shear stress in the AAC and ' $a$ ' is the height of the grout filled key joint or thickness (vertical dimension) of panel/bond beam, depending on the contact height. Dimensions for the key joint are given in the detail at the end of this subsection.

$$\text{Area of shear reinforcement ( } A_{vf} \text{): } A_{vf} = \frac{V_u}{\mu f_s}$$

where ' $V_u$ ' is the design shear force, ' $\mu$ ' is the coefficient of friction equal to 0.45, and  $f_s$  is the allowable tensile stress in the reinforcement.

### Diaphragm Design Example:

Material properties:

Strength class: AAC4/500       $f'_{grout} = 3000$  psi  $f_y = 60000$  psi

Factored Wind Load  $W_u = 11520$  lb

Ring Beam  $A_s = .38$  in<sup>2</sup> (2 #4)

Key Joint  $A_s = .11$  in<sup>2</sup> (1 #3)

### Diaphragm Design:

Flexure –

$$M_u = \frac{W_u \ell}{4} = \frac{11520 \cdot 60}{4} = 172800 \text{ lb} \cdot \text{ft} = 2073600 \text{ lb} \cdot \text{in}$$

$$T = A_s f_y = 0.38 \cdot 60000 = 22800 \text{ lb}$$

$$a = \frac{C}{0.85 \cdot f'_{grout} \cdot b} = \frac{22800}{0.85 \cdot 3000 \cdot 8} = 1.12 \text{ in}$$

$$d = 240 - 5 = 235$$

$$M_n = A_s f_y \left( d - \frac{a}{2} \right) = 0.38 \cdot 60000 \cdot \left( 235 - \frac{1.12}{2} \right) = 5345232 \text{ lb} \cdot \text{in}$$

$$\phi M_n > M_u \therefore \text{OK}$$

Shear @ panel – ring beam joint:

$$V_{\text{grout}} = \tau_g b_g \ell = 36 \cdot 8 \cdot 230 = 66240 \text{ lb}$$

$$\phi V_{\text{total}} = 0.67 \cdot 66240 = 44380 \text{ lb} > V_u = 5760 \text{ lb} \therefore \text{OK}$$

## 5A.15 AAC Block Design Examples

### Design of an AAC Shear Wall

Design the two-story AAC shear wall shown below. The material properties, factored loads, and geometry are defined as follows:

Strength Class: AAC-4/500

Design Density: 44 pcf

Minimum Compressive Strength:  $f'_{AAC} = 580 \text{ psi}$

$f_y = 60,000 \text{ psi}$  (flexural reinforcement)

$E_s = 29,000 \text{ ksi}$

Factored axial load at each story,  $P_u = 35,000 \text{ lbs}$

Factored lateral load at each story,  $F_u = 15,000 \text{ lbs}$

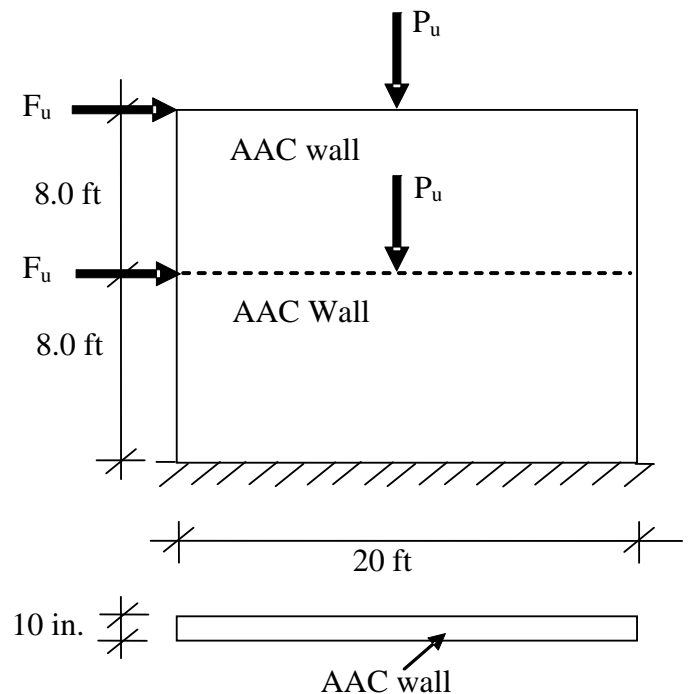



## Flexural Capacity

a) Determine factored bending moment at the base of the wall.

$$M_u = 15,000(16)(12) + 15,000(8.0)(12) = 4,320,000 \text{ lbs} - \text{in.}$$

b) Determine flexural capacity at the base of the wall.

Assume flexural reinforcement at wall ends only, equal to 1 # 4 bar, located 24 in. from the wall ends.

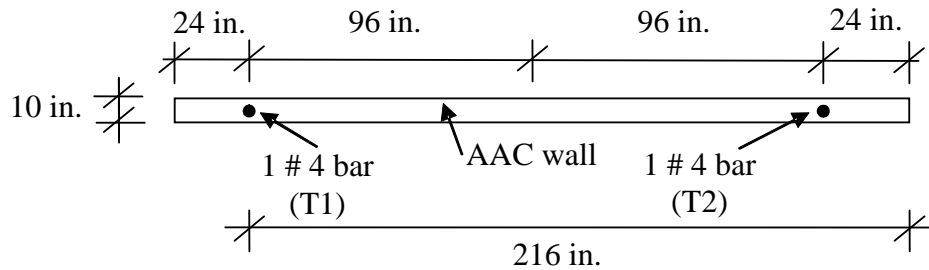

Calculate forces in bars ( $T_1$  and  $T_2$ ) assuming that both bars are yielding.

$$T_1 = T_2 = A_s f_y = 0.2(60,000) = 12,000 \text{ lbs}$$

For equilibrium:

$$C = N_u + T_1 + T_2$$

Factored Weight of Wall =  $(1.2)(10\text{in}/12)(44\text{pcf})(8\text{ft})(20\text{ft}) = 7040 \text{ lbs}$

$$N_u = 2(P_u) = 35,000 + 35,000 + 7040 + 7040 = 84,080 \text{ lbs}$$

$$C = 0.85 f'_{AAC} a b$$

$$a = \frac{C}{0.85 f'_{AAC} b} = \frac{84,080 + 12,000(2)}{0.85(580)(10)} = 21.9 \text{ in.}$$

$$M_n = T_1 \left( 216 - \frac{l_w}{2} \right) - T_2 \left( \frac{l_w}{2} - 24 \right) + C \left( \frac{l_w - a}{2} \right)$$

$$M_n = 12,000 \left( 216 - \frac{240}{2} \right) - 12,000 \left( \frac{240}{2} - 24 \right) + 108,080 \left( \frac{240 - 21.9}{2} \right) = 11,786,124 \text{ lbs}$$

$$\phi M_n = 0.9 (11,786,124) = 10,607,512 \text{ lbs}$$

$$\Phi M_n = 10,607,512 \text{ lbs-in.} > M_u = 4,320,000 \quad \text{OK}$$

Check if right bar ( $T_2$ ) is yielding.

$$c = \frac{a}{\beta_1} = \frac{21.9}{0.67} = 32.7 \text{ in.}$$

$$\varepsilon_2 = \frac{24}{32.7} (\varepsilon_{AAC}) = \frac{24}{32.7} (0.003) = 0.0022$$

$$\varepsilon_y = \frac{f_y}{E_s} = \frac{60,000}{29,000,000} = 0.0021$$

$$\varepsilon_2 = 0.0022 > \varepsilon_y = 0.0021 \quad \text{OK}$$

### Shear capacity

a) Determine factored shear force and axial force at the base of the wall.

$$V_u = 2 F_u = 2 (15,000) = 30,000 \text{ lbs}$$

$$N_u = 84,080 \text{ lbs}$$

b) Determine shear capacity at the base of the wall (web shear cracking).

$$\phi V_{AAC} = \phi 0.86 t l_w \sqrt{f'_{AAC}} \sqrt{1 + \frac{N_u}{2.4 \sqrt{f'_{AAC}} t l_w}}$$

$$\phi V_{AAC} = 0.75 (0.86) (10) (240) \sqrt{580} \sqrt{1 + \frac{84,080}{2.4 \sqrt{580} (10) (240)}} = 47,247 \text{ lbs}$$

$$\Phi V_{AAC} = 47,247 \text{ lbs} > V_u = 30,000 \text{ lbs} \quad \text{OK}$$

c) Determine factored shear force and axial force at 7.5 ft from the base of the wall.

$$V_u = F_u = 15,000 \text{ lbs}$$

$$P_u = N_u = 42,040 \text{ lbs}$$

d) Determine shear capacity at 7.5 ft from the base of the wall (web shear cracking).

$$\phi V_{AAC} = 0.75(0.86)(10)(240)\sqrt{580} \sqrt{1 + \frac{42,040}{2.4\sqrt{580}(10)(240)}} = 42,557 \text{ lbs}$$

$$\Phi V_{AAC} = 42,557 \text{ lbs} > V_u = 15,000 \text{ lbs} \quad \text{OK}$$

e) Determine shear capacity at base of wall (crushing of the diagonal strut).

$$\phi V_{AAC} = 0.75(0.9)f'_{AAC} t w_{\text{strut}} \frac{h \left( \frac{3l_w}{4} \right)}{h^2 + \left( \frac{3l_w}{4} \right)^2}$$

$$w_{\text{strut}} = \frac{l_w}{4} = \frac{240}{4} = 60 \text{ in}$$

$$\phi V_{AAC} = 0.75(0.9)(580)(10)(60) \frac{90 \left( \frac{3(240)}{4} \right)}{90^2 + \left( \frac{3(240)}{4} \right)^2} = 93,960 \text{ lbs}$$

$$\Phi V_{AAC} = 93,960 \text{ lbs} > V_u = 30,000 \text{ lbs} \quad \text{OK}$$

f) Determine sliding shear capacity at bottom of wall with a thin-bed mortar joint.

$\mu = 1$  at a leveling bed joint

$$\phi V_{ss} = \phi(\mu N_u)$$

Neglect additional force in tensile steel.

$$\phi V_{ss} = 0.75 ( (1)(84,080) ) = 63,060 \text{ lbs}$$

$$\phi V_{ss} = 63,060 \text{ lbs} > V_u = 30,000 \text{ lbs} \quad \text{OK}$$

$\mu = 0.75$  at a leveling bed joint

$$\phi V_{ss} = \phi ( \mu N_u )$$

Neglect additional force in tensile steel.

$$\phi V_{ss} = 0.75 ( (0.75)(84,080) ) = 47,295 \text{ lbs}$$

$$\phi V_{ss} = 47,295 \text{ lbs} > V_u = 30,000 \text{ lbs} \quad \text{OK}$$

**DISCLAIMER.** This document is not intended to replace the knowledge, experience and judgment of design professionals. Xella Aircrete North America, Inc. is **not** responsible for ensuring weather-tightness, overall functionality or fitness for use of the panels, nor compliance with federal, state, or local laws, ordinances or regulations, including building, environmental and other codes.

**WARNING.** Property damage, personal injury or death may result from improper design, use, or installation. Licensed design and construction professionals, who maintain good standing with the governing authority and have the necessary knowledge, experience and judgment of the specific building system and its components, should be retained to ensure a proper design, use, and installation.

**MODIFICATIONS.** Xella Aircrete North America, Inc. reserves the right to change its Technical Manual, Design Guide, safe working loads, panel dimensions or installation techniques at any time without prior notice. Last modified: 10/12/2010. . Version 1.2

**WARRANTY/DAMAGES.** This document and all further technical advice are based upon Xella Aircrete North America, Inc.'s present knowledge and experience. However, Xella Aircrete North America, Inc. assumes no liability for providing such information and advice. Xella Aircrete North America, Inc. disclaims all CONDITIONS AND WARRANTIES, WHETHER EXPRESS OR IMPLIED, INCLUDING THE IMPLIED WARRANTIES OF FITNESS FOR A PARTICULAR PURPOSE OR MERCHANTABILITY. XELLA AIRCRETE NORTH AMERICA, INC. SHALL NOT BE RESPONSIBLE FOR CONSEQUENTIAL, INDIRECT OR INCIDENTAL DAMAGES (INCLUDING LOSS OF PROFITS or USE) OF ANY KIND.